

CASE REPORT

DOUBLE TRANSLOCATION: AN INTERESTING FAMILY HISTORY

Uysal A^{1,*}, Uludağ A², Sılan F², Erçelen N³, Zafer C⁴, Özdemir Ö²

***Corresponding Author:** Assistant Professor Ahmet Uysal, Department of Obstetrics and Gynecology, Çanakkale Onsekiz Mart University, Çanakkale, Turkey; Tel.: +90-533-263-55-40; Fax: +90-0286-263-59-56; E-mail: drahmetuysal@hotmail.com

ABSTRACT

Double balanced translocations are particularly rare and the risk of a fetus with an unbalanced chromosomal anomaly is greater than for single translocation carriers. In this present case, we describe an interesting family history which included three generations. A couple, married for 4 years, was referred to the genetic clinic due to infertility and family chromosome anomalies. A GTG-band chromosome analysis indicated that the male partner's karyotype was 45,XY, t(3;18)(q11;ptel)t(13;14)(q10;q10). The same double balanced translocation was found in two others family members.

Keywords: Double translocation; Robertsonian translocation; Fluorescent *in situ* hybridization (FISH); Miscarriage.

INTRODUCTION

Parental chromosomal irregularity was first proposed as a cause of recurrent spontaneous abortion in 1967. In the years following various studies on couples with a history of two or more spontaneous

miscarriages found rates of chromosomal irregularity as low as 2.0% and as high as 17.75%. In spite of different rates of chromosomal irregularity found in these studies, reciprocal or Robertson-type balanced translocations (average 4.03%) were highest followed by other irregularities such as inversion and gonosomal chromosome mosaicism [1,2].

For patients recognized as carriers of reciprocal or Robertson-type translocations, chromosome analysis of parents and known first-degree relatives can determine whether the translocation is *de novo* or familial. While chromosomal translocations are seen in 0.2% of newborns, this rises to 2.5% in couples with repeated unsuccessful conceptions and is 9.2% in couples with repeated miscarriages [2-4].

Robertsonian translocations occur when the p arm (satellite) of a series coding repetitive ribosomal RNA of two acrocentric chromosomes (13, 14, 15, 21, 22) is lost and combines with the q arm centromere. While balanced reciprocal translocation does not have loss between two non homologous chromosomes, it mainly occurs due to displacement of the end regions of the chromosomes [3,4].

Before preimplantation genetic diagnosis (PGD) can be carried out for translocation carriers, a preparation stage must be completed. This stage in a couple recognized as translocation carriers by cytogenetic analysis verifies fracture points by fluorescent *in situ* hybridization (FISH) analysis and is very important in determining which probes will be used in PGD studies. This requires blood samples from both partners for chromosome examination and recording fracture

¹ Department of Obstetrics and Gynecology, Çanakkale Onsekiz Mart University, Çanakkale, Turkey

² Department of Medical Genetics, Çanakkale Onsekiz Mart University, Çanakkale, Turkey

³ Department of Medical Genetics, Vehbi Koç Vakfı (VKV) American Hospital, Istanbul, Turkey

⁴ Department of Biology, Abant İzzet Baysal University, Bolu, Turkey

points on the chromosomes using the FISH method. Again, if the candidate father was a translocation carrier, it may have been possible to determine the normal or balanced/unbalanced gamete ratio using FISH analysis of sperm cells before the PGD procedure was implemented. The FISH analysis of sperm cells, especially in reciprocal translocation carriers, is very useful to estimate the balanced/unbalanced embryo ratio and as a treatment indicator [5].

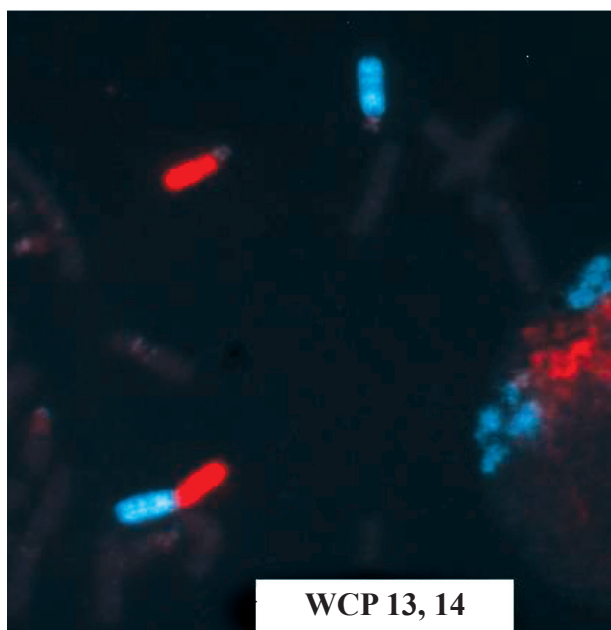
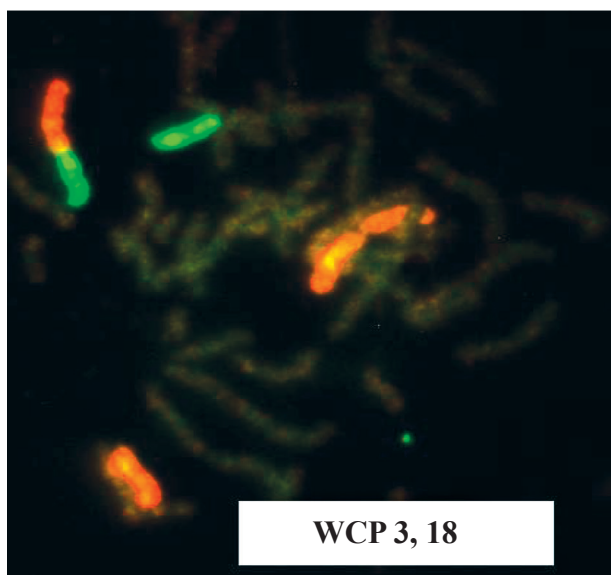

Figure 1. Fluorescent *in situ* hybridization image of male partner (IV-5) with karyotype 45,XY,t(3;18)(q11; p11)t(13;14)(q10;q10). Orange signal is 3, green signal is 18, blue signal is 13 and red signal for chromosome 14.

This study investigated a couple who applied to our clinic due to infertility and a history of family chromosomal anomalies. The male partner was a balanced double translocation carrier and the history of other members of the family was researched.

Case Report. A couple married for 4 years was referred to the genetic clinic due to infertility and family chromosome anomalies. A GTG-band chromosome analysis indicated 46,XX normal and 45,XY,t(3;18)(q11; p11)t(13;14)(q10;q10) karyotypes. The male partner (IV-5) (Figure 1) was phenotypically normal with normal intelligence and healthy other than infertility. His sister (IV-8) who experienced repeated miscarriages was found carried the same double translocation. The FISH analysis was done again and confirmed the karyotype. For FISH, WC 13 blue, WC 14 red, (Poseidon DNA Probes, Kretech Biotechnology, Amsterdam, The Netherlands); WCP 3, spectrum orange, WCP 18, spectrum green, WCP (Whole Chromosome Paint) (Vysis Inc., Downers Grove, IL, USA) were used. Other members of the family were called for chromosome analysis and the proband's mother (III-6), who had two miscarriages and three healthy children, carried the same double translocation. The proband's single sister (IV-10) (Figure 2) carried only reciprocal translocation, while the proband's grandfather (II-4) (Figure 3) only carried a Robertsonian translocation. The mother (III-6) had a brother and sister who both died from congenital anomalies at

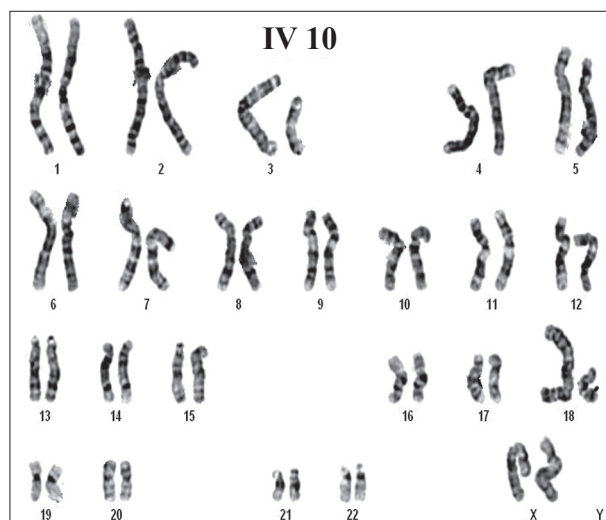

Figure 2. Karyotype image of the proband's sister (IV-10) carried only reciprocal translocation of chromosomes 3 and 18.

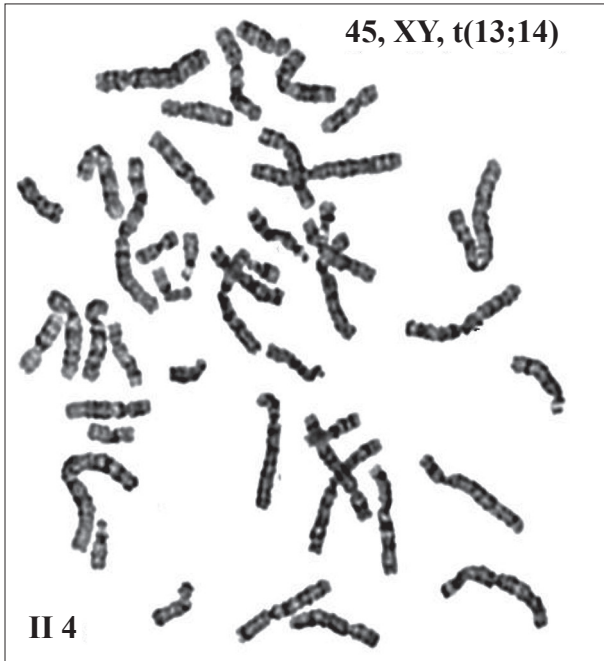

Figure 3. Karyotype image of the proband's grandfather (II-4) 45,XY,t(13;14).

age 6 months and a brother who died from cancer of the pharynx at age 37. The mother's only living sibling had normal chromosome analysis results (Figure 4). Analysis of the proband's sperm found a normal 50 million/mL sperm count, however, morphologic evaluation using the Kruger method found 99.0% teratospermia with head anomalies. Using the intra cy-

toplasmic sperm injection (ICSI) method on the proband's wife, two late divided embryos were obtained from seven eggs and transferred on the third day; however, β -human chorionic gonadotropin (β -HCG) had not increased on the 12th day after transfer. Genetic counseling was provided to the proband's wife and sister; in light of PGD, *in vitro* fertilization (IVF) was presented as an option.

DISCUSSION

Individuals who are carriers of balanced chromosome irregularities may have it packaged differently, but still have all their genetic information. For this reason, balanced reciprocal and Robertson-type translocation carriers are phenotypically normal, however they have a significant increased risk of unbalanced gamete production and abnormal progeny [4,5]. Our patient, together with other family members carrying anomalies, was phenotypically normal. Our male proband's mother and sister, both carriers, had repeated miscarriages. In pregnancies of chromosomal translocation-carrying couples, if an embryo with a chromosomal make-up incompatible with life (*e.g.*, autosomal monosomy), miscarriage, intrauterine fetal death or still-birth may occur. Embryos with unbalanced chromosomal make-up compatible with life may result in a baby with congenital anomalies at birth, birth of a balanced trans-location carrier of

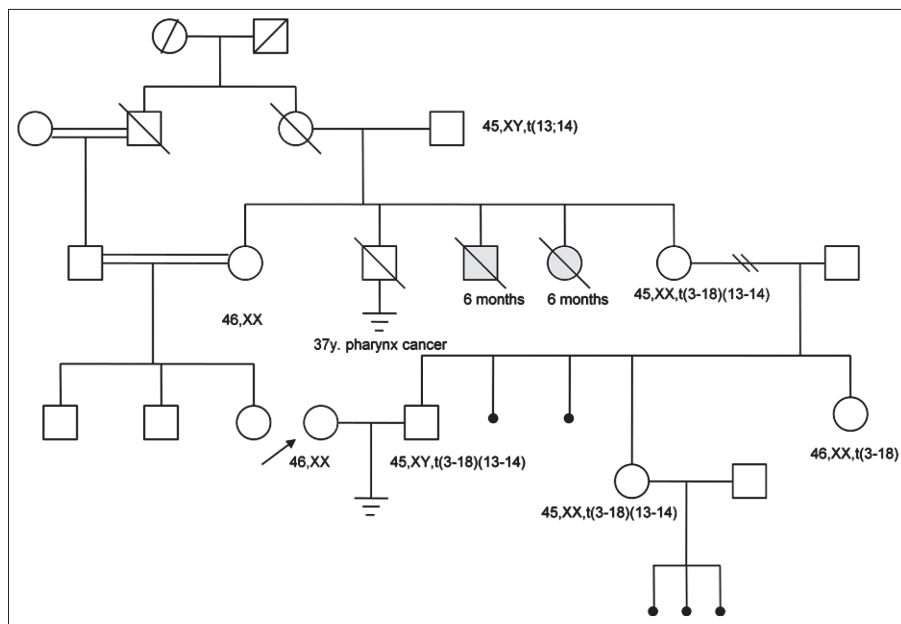

Figure 4. Pedigree of the studied family.

normal phenotype (similar to the parents) or birth of a chromosomally normal, completely healthy baby [5].

Due to risk of unbalanced chromosomal anomalies compatible with life or of a fetus with congenital anomalies, pregnancies of balanced translocation carriers which do not end in miscarriage are indicated for amniocentesis and chromosome analysis. However, as with our patient, translocation carriers may not be identified if pregnancies end very early, even though it may be the cause of sterility or infertility due to miscarriage. The success rate of IVF before PGD is low. For translocation carriers, assisted reproduction techniques combined with PGD, increase the probability of viable pregnancy [2,4,5].

Double balanced translocations are particularly rare and the risk of a fetus with unbalanced chromosomal anomaly is greater than for single translocation carriers [5,6]. In the family presented here, the interesting point is that though the two siblings with double translocation were infertile, their mother, with the same double translocation, had three healthy children, only two miscarriages and no complaint of infertility.

Balanced chromosomal translocations have a frequency of 0.3% in the general population. Similar studies on couples with spontaneous miscarriages found a frequency of 4.03% for balanced translocations, much greater than that of the general population. It is thought that in addition to being an important cause of abortus, balanced translocations increase the frequency of total chromosome irregularities in offspring (7.63%), and is an important etiologic factor in spontaneous abortions, stillbirth and malformations at birth [1,3,4,5]. In conclusion, we believe that couples with recurrent spontaneous abortions, together with infertile couples, should be advised to have chromosome analysis.

REFERENCES

1. Ward BE, Henry GP, Robinson A. Cytogenetic studies in 100 couples with recurrent spontaneous abortions. *Am J Hum Genet* 1980; 32(4): 549-554.
2. Crolla JA, Youings SA, Ennis S, Jacobs PA. Super-numerary marker chromosomes in man: parental origin, mosaicism and maternal age revisited. *Eur J Hum Genet*. 2005; 13(2): 154-160.
3. Kochhar PK, Ghosh P. Reproductive outcome of couples with recurrent miscarriage and balanced chromosomal abnormalities. *J Obstet Gynaecol Res*. 2013; 39(1): 113-120.
4. Alfarawati S, Fragouli E, Colls P, Wells D. Embryos of Robertsonian translocation carriers exhibit a mitotic interchromosomal effect that enhances genetic instability during early development. *PLoS Genet*. 2012; 8(10): e1003025. doi: 10.1371/journal.pgen.1003025.
5. Ogilvie CM, Braude P, Scriven PN. Successful pregnancy outcomes after preimplantation genetic diagnosis (PGD) for carriers of chromosometranslocations. *Hum Fertil (Camb)*. 2001; 4(3): 168-171.
6. Bowser-Riley SM, Griffiths MJ, Creasy MR, Farndon PA, Martin KE, Thomson DA, *et al*. Are double translocations double trouble? *J Med Genet*. 1988; 25(5): 326-331.